

SYCAMORE TOWNSHIP, OH
 DEPARTMENT OF PLANNING & ZONING
 8540 KENWOOD ROAD, CINCINNATI, OH 45236

513.792.7250 PHONE 513.792.8564 FAX

RECEIVED
 APR 29 2019
 SYCAMORE TWP

BZA APPLICATION	
FEES:	
APPEAL:	\$150.00
VARIANCE:	\$150.00
CONDITIONAL USE:	\$500.00
NON-CONFORMING USE:	\$500.00

COMMERCIAL	RESIDENTIAL
	✓

APPLICATION NUMBER
 SYCBI90009
 DO NOT WRITE IN THIS SPACE

1. PROJECT ADDRESS: 8076 Queen Ave ZIP CODE: 45236

2. NAME	STREET ADDRESS	CITY	ST	ZIP	PHONE NUMBER
OWNER Cecilia Allison Marshall	8076 Queensave	Cincinnati	OH	45236	859640-7817 513 470-5997
CONTRACTOR Rick Curtis					
DESIGNER Rick Curtin	3605 E Galbraith				513-283-4809
APPLICANT Rick Curtis	3605 E Galbraith				''''
APPLICANTS E-MAIL ADDRESS					

3. BZA ACTION REQUESTED: APPEAL VARIANCE
 CONDITIONAL USE NON-CONFORMING USE

4. STATE IN DETAIL ALL EXISTING & PROPOSED USES OF THIS BUILDING OR PREMISES:

Retaining wall to level driveway
Prevent water seeping

5. SQUARE FEET: 1400 6. USE: DRIVEWAY 7. HEIGHT: _____
 8. EST. START DATE: _____ 9. EST. FINISH DATE: _____

THE DEPARTMENT OF PLANNING & ZONING IS DEDICATED TO THE CONTINUING PROSPERITY OF SYCAMORE TOWNSHIP. WE PROMOTE HIGH STANDARDS FOR DEVELOPMENT AND QUALITY PROJECTS. WE LOOK FORWARD TO SERVING OUR CITIZENS AND BUSINESS COMMUNITY TO MAKE SYCAMORE TOWNSHIP THE BEST IT CAN BE.

The owner of this project and undersigned do hereby certify that all of the information and statements given on this application, drawings and specifications are to the best of their knowledge, true and correct. The applicant and owner of the real property agree to grant Sycamore Township access to the property for review and inspection related to this Board of Zoning Appeals application.

NOTE: FILING THIS APPLICATION DOES NOT CONSTITUTE PERMISSION TO BEGIN WORK.

Alia L. L... 4/29/19
 APPLICANT'S SIGNATURE DATE
[Signature] _____
 PROPERTY OWNER'S SIGNATURE DATE

DO NOT WRITE BELOW THIS LINE

To Sycamore Township Board of Zoning Appeals

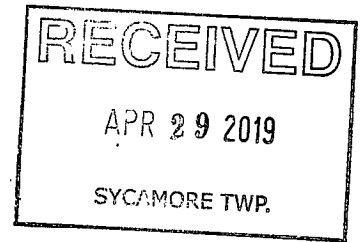

8076 Queens Ave 45236 6273 sq ft lot

Wanting to level driveway at said residence and a small retaining wall is required

Not only to level driveway but also to prevent water shedding due to the high grade of house

Hamilton county inspector said that wall is required in order for Hamilton County to approve the driveway

Driveway improvement needed because east side of driveway was starting to collapse

And driveway above culvert was deteriorating due to improper drainage

Respectfully

Rick Curtis

Rick Curtis 513-283-4809

Greg Marshall

Greg Marshall 659-640-7817

RECEIVED

APR 29 2019

SYCAMORE TWP.

8096

8101

846

848

846

848

8076

850

4564

846

850

Queens Av

Theodore Av

8076 QUEEN'S AVE

END WALL T.W. = 850 ±

STA. 0+60 ± GR = 848 ±

24" HIGH
T.W. = 850 ±
GR = 848 ±

WALL 'A'

BEGIN WALL T.W. = 849.3 ±

STA. 0+00 GR = 848 ±

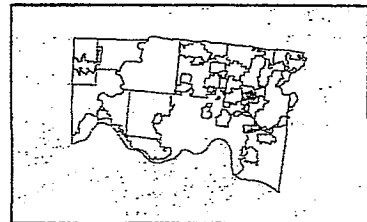
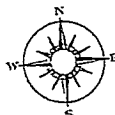
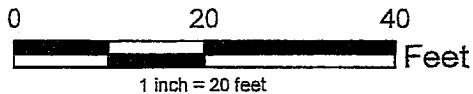

THE PROVIDER MAKES NO WARRANTY OR REPRESENTATION, EITHER EXPRESSED OR IMPLIED WITH RESPECT TO THIS INFORMATION, ITS QUALITY, PERFORMANCE, MERCHANTABILITY, OR FITNESS A PARTICULAR PURPOSE, AS A RESULT THIS INFORMATION IS PROVIDED AS IS, AND YOU, THE REQUESTER, ARE ASSUMING THE ENTIRE RISK AS TO ITS QUALITY AND PERFORMANCE.

Data Provided By: CAGIS

Date: 3/15/2019

Map Created By: rtoelke

IN NO EVENT WILL THE PROVIDER BE LIABLE FOR DIRECT, INDIRECT, INCIDENTAL, OR CONSEQUENTIAL DAMAGES RESULTING FROM ANY DEFECT IN THE INFORMATION, EVEN IF ADVISED OF THE POSSIBILITY OF SUCH DAMAGES. IN PARTICULAR, THE PROVIDER SHALL HAVE NO LIABILITY FOR ANY OTHER INFORMATION, PROGRAMS OR DATA USED WITH OR COMBINED WITH THE REQUESTED INFORMATION, INCLUDING THE COST OF RECOVERING SUCH INFORMATION, PROGRAMS OR DATA

Hamilton County Engineer's Office
Theodore B. Hubbard, P.E.-P.S. County Engineer
www.hamilton-co.org/engineer

RECEIVED

APR 29 2019

SYCAMORE TWP.

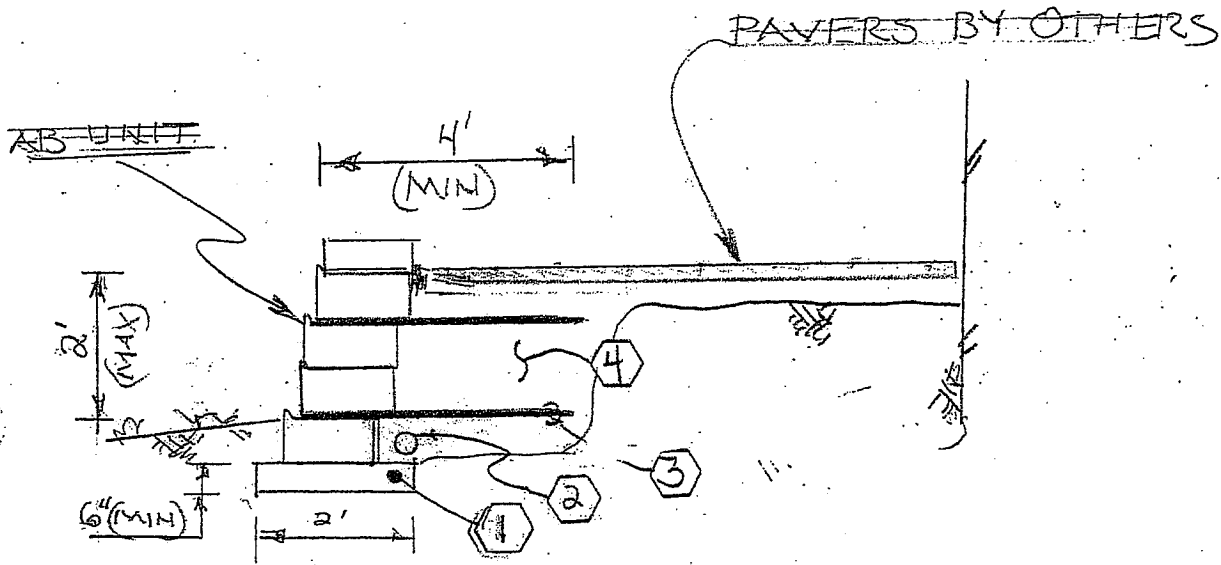

TYPICAL SECTION

N.G.S.

- ① ~~ODOT #41 DENSE GRADE BASE COURSE~~
- ② ~~4\"/>~~
- ③ ~~AB GRID (TYP)~~
- ④ ~~#57 AGGREGATE REINFORCED ZONE~~

▷ ~~COMPACT BASE COURSE & REINFORCED ZONE~~
~~≥ 98% STD. PROCTOR DENSITY PER ASTM D698~~

RECEIVED
 APR 29 2019
 SYCAMORE TWP.

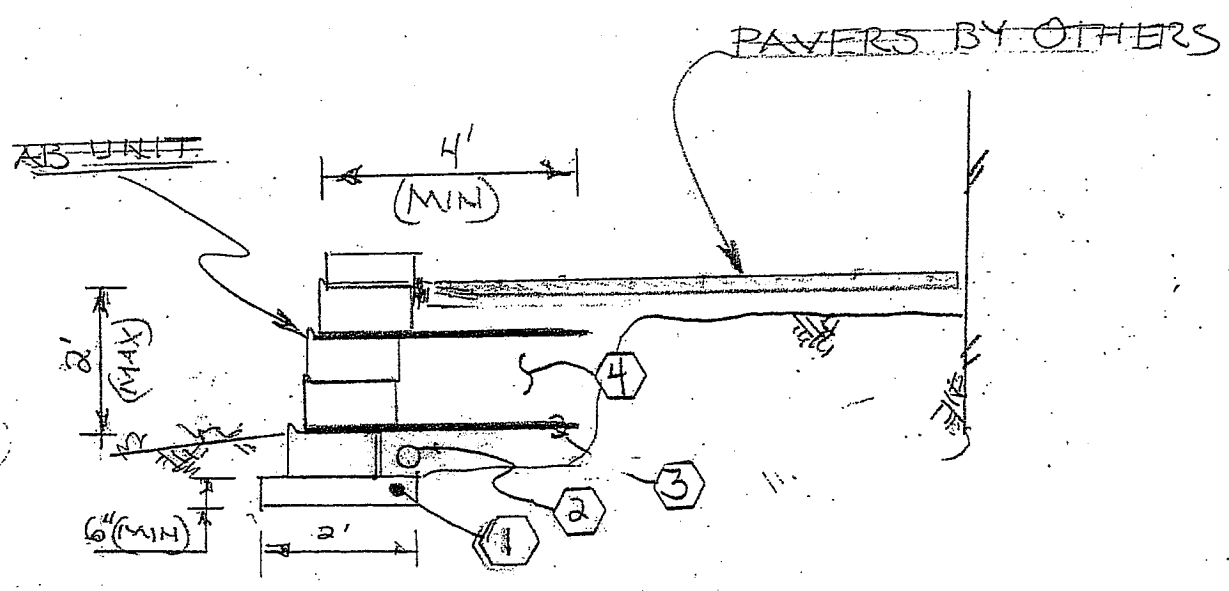

TYPICAL SECTION
 N.T.S.

- ① ~~ODOT #41 DENSE GRADE BASE COURSE~~
 - ② ~~4" PERF. DRAIN TILE~~
 - ③ ~~AB GRID (TYP)~~
 - ④ ~~57 AGGREGATE REINFORCED ZONE~~
- ▷ ~~COMPACT BASE COURSE & REINFORCED ZONE~~
~~≥ 98% STD. PROCTOR DENSITY PER ASTM D698~~